

Updated 02/05/2010 – Camry VIN Range
Updated 02/04/2010 – Update to VIN Range, Q&A, and Owner Letter
Previous versions of these documents should be discarded.

Toyota Motor Sales, U.S.A., Inc.
19001 South Western Avenue
Torrance, CA 90501
(310) 468-4000

February, 2010

To: All Toyota Dealer Principals, Service Managers, Parts Managers
Subject: Safety Recall (Special Service Campaign) – A0A
Accelerator Pedal Modification Campaign
Vehicles Equipped with Accelerator Pedals Manufactured by CTS Corporation

On January 21, 2010, Toyota filed a Defect Information Report (DIR) with the National Highway Traffic Safety Administration (NHTSA) informing the agency of our intent to conduct a voluntary Safety Recall on vehicles equipped with certain accelerator pedal assemblies manufactured by the CTS Corporation (CTS accelerator pedals). This action is separate from the on-going recall (SSC 90L) of approximately 4.2 million Toyota and Lexus vehicles to reduce the risk of pedal entrapment by incorrect or out of place accessory floor mats.

Background

There is a possibility that certain accelerator pedal mechanisms may mechanically stick in a partially depressed position or return slowly to the idle position. Over time, the internal mechanisms in the accelerator pedal may become worn. As a result of this wear combined with certain operating and environmental conditions, friction in the mechanism may increase and intermittently result in the accelerator pedal being hard to depress and/or slow to return or, in the worst case, stick in a partially open position, increasing the risk of a crash.

Toyota dealers are requested to install a precision-cut steel reinforcement bar (“reinforcement bar”) that will increase the clearance in between the internal mechanisms in the pedal assembly. This increased clearance will reduce the friction caused by wear and environmental conditions and allow the pedal to operate smoothly for the life of the vehicle. The safety recall remedy will be performed at **no charge** to the vehicle owner.

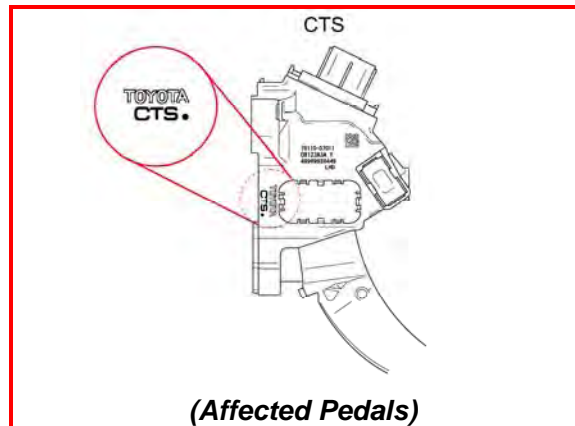

Note:

- ***The name of the manufacturer is printed (Denso) or embossed (CTS) on the upper sensor housing on the brake pedal side.***
- ***This safety campaign addresses the potential for a CTS accelerator pedal to mechanically stick in a partially depressed position or return slowly to the idle position.***
- ***This condition is separate from the (DIR) filed in early October, 2009, in reference to the potential for an incorrect or improperly installed floor mat to interfere with the accelerator pedal.***

The following vital information is provided to inform you and your staff of the owner notification phase of the campaign and your degree of involvement.

1. Owner Notification Mailing Date

The owner notification will begin in early February, 2010.

Please note that only owners of the affected vehicles will be notified. If you are contacted by an owner who has not yet received a notification, please **verify eligibility by confirming through Dealer Daily/TIS prior to performing repairs**. Dealers should perform the repair as outlined in the Technical Instructions found on TIS.

2. Vehicles in Dealer Stock

As required by Federal law, dealers are not to deliver any new vehicles in their inventory, which are involved in this safety recall. Dealers must perform the safety recall on all new vehicles in stock prior to sale or lease. Vehicle safety recall completion can be verified through TIS.

In order to assure established customers receive priority for the safety recall, we request that this campaign remedy be performed on in-stock vehicles just prior to vehicle delivery where possible.

A VIN list containing vehicles in dealer stock, has been provided for your reference.

3. Dealer Summary Reports

For your reference, the following summary reports are included for the CSOM and Director of Service:

- **The suggested initial parts order quantities**
- **A VIN list containing vehicles in dealer stock**
- **Dealer Reports will no longer contain a PMA VIN list.** However, they will contain the number of involved vehicles registered in each dealership’s primary marketing area and initial suggested parts order quantities, where applicable.

4. Number of Vehicles Involved

There are approximately 2.23 million Toyota vehicles equipped with a CTS pedal in the U.S.

MODEL	WMI	MY	VDS	START - FINISH
AVALON	4T1	2005	BK36B	U001003 - U062426
		2006	BK36B	U042154 - U167717
		2007	BK36B	U149048 - U253880
		2008	BK36B	U209130 - U324241
		2009	BK36B	U305357 - U351925
		2010	BK3DB	U351302 - U367444

AVALON UIO: 330,000

MODEL	WMI	MY	VDS	START - FINISH
COROLLA	1NX	2009	BE40E	Z001001 - Z163790
			BU40E	Z001002 - Z165305
		2010	BE4EE	Z165306 - Z333282
			BU4EE	Z165312 - Z337444
	2T1	2009	BE40E	C001043 - C030479
			BU40E	C001054 - C191051
		2010	BE4EE	C030504 - C039875
			BU4EE	C185955 - C348040

COROLLA UIO: 490,000

MODEL	WMI	MY	VDS	START - FINISH	
CAMRY*	4T1	2007	BE46K	U001001 - U195222	
				U504376 - U729526	
		2008	BK46K	U001003 - U054581	
			BE46K	U171709 - U263248	
		2009		U730123 - U791444	
			BK46K	U040415 - U073251	
		2010	BE46K	U260017 - U416640	
			BK46K	U073252 - U098189	
		4T4	BF3EK	U001001 - U112408	
			BK3EK	U091136 - U116164	
			2007	BE46K	R001003 - R011624
			2008	BE46K	R001816 - R047779
2009	BE46K	R027105 - R139848			
2010	BF3EK	R001023 - R085180			

CAMRY UIO: 786,000

*Camry Hybrid vehicles are equipped with an accelerator pedal that is of a different design and produced by a different supplier. Therefore, it does not require the installation of an accelerator pedal reinforcement bar.

(Number of Vehicles Involved Continued. . .)

MODEL	WMI	MY	VDS	START - FINISH
HIGHLANDER*	5TD	2010	BK3EH	S001052 - S013868
			DK3EH	S001067 - S013863
			EK3EH	S001051 - S008434
			JK3EH	S005002 - S013869
			KK3EH	S003272 - S008683
			XK3EH	S001026 - S005688
			YK3EH	S001030 - S008686
			ZA3EH	S001019 - S003107
			ZK3EH	S001020 - S008685

HIGHLANDER UIO: 20,000

**Highlander Hybrid vehicles are equipped with an accelerator pedal that is of a different design and produced by a different supplier. Therefore, it does not require the installation of an accelerator pedal reinforcement bar.*

MODEL	WMI	MY	VDS	START - FINISH
SEQUOIA	5TD	2008	BT64A	S000014 - S000239
			BY64A	S000047 - S023603
			BY67A	S000042 - S023596
			BY68A	S000034 - S023597
			ZT64A	S000014 - S000384
			ZY64A	S000010 - S015402
			ZY67A	S000012 - S015400
			ZY68A	S000013 - S015401
		2009	BT64A	S000244 - S001152
			BW68A	S023606 - S023606
			BY64A	S023711 - S023868
			BY67A	S023609 - S023857
			BY68A	S023616 - S023856
			ZT64A	S000438 - S000953
			ZY64A	S019566 - S020863
			ZY67A	S015919 - S015919
		ZY68A	S015426 - S021051	
		2010	BM5G1	S001002 - S001225
			BW5G1	S023880 - S032694
			BY5G1	S023869 - S032719
			DW5G1	S023878 - S032718
			DY5G1	S023870 - S032709
			JW5G1	S023876 - S032713
			JY5G1	S023871 - S032708
			KM5G1	S001417 - S001458
			KY5G1	S022514 - S027553
			YY5G1	S022511 - S027563
			ZM5G1	S001034 - S002051
			ZY5G1	S022519 - S027561
			ZY67A	S020526 - S020527

SEQUOIA UIO: 50,000

MODEL	WMI	MY	VDS	START - FINISH
MATRIX	2T1	2009	GE40E	C001023 - C005748
			KE40E	C001042 - C030591
			KU40E	C001057 - C191049
			LE40E	C001017 - C011935
		2010	KE4EE	C030606 - C039888
			KU4EE	C191054 - C348047
			LE4EE	C011822 - C016115
			ME4EE	C005690 - C006299

MATRIX UIO: 75,000

MODEL	WMI	MY	VDS	START - FINISH
RAV4	2T3	2009	BF31V	W001119 - W024119
			BF32V	W001207 - W024120
			BF33V	W001117 - W024117
			BF34V	W003775 - W021681
			BF35V	W001421 - W024111
			BK31V	W001143 - W013774
			BK32V	W001142 - W013693
			BK33V	W001162 - W013773
			BK34V	W001688 - W010762
			BK35V	W002139 - W013749
			ZF31V	W001050 - W016880
			ZF32V	W001048 - W016874
			ZF33V	W001049 - W016918
			ZF34V	W003810 - W012950
			ZF35V	W001625 - W016916
			ZK31V	W001081 - W003645
			ZK32V	W001149 - W003642
			ZK33V	W001076 - W003644
		ZK34V	W001670 - W002621	
		ZK35V	W001965 - W003631	
		2010	BF4DV	W022899 - W038726
			BK4DV	W013775 - W020737
			DF4DV	W024130 - W038723
			DK4DV	W013776 - W020732
			EF4DV	W024745 - W035186
			EK4DV	W014634 - W020625
			JF4DV	W024129 - W038700
			JK4DV	W013811 - W020629
			KF4DV	W016950 - W027204
			KK4DV	W003824 - W005660
			RF4DV	W022777 - W038716
			RK4DV	W013813 - W020685
			WF4DV	W016936 - W027202
			WK4DV	W003659 - W005669
			XF4DV	W018112 - W025585
			XK4DV	W003701 - W005572
			YF4DV	W016920 - W027201
			YK4DV	W003435 - W005673
			ZF4DV	W016923 - W027211
			ZK4DV	W003652 - W005662

RAV4 UIO: 53,000

(Number of Vehicles Involved Continued. . .)

MODEL	WMI	MY	VDS	START - FINISH
TUNDRA	5TB	2007	BT541	S449772 - S458203
			BT581	S449768 - S458119
			BV541	S449818 - S490980
			BV581	S449815 - S490940
			DT541	S452172 - S458112
			DT581	S451402 - S457120
			DV541	S454929 - S490979
			DV581	S454922 - S490970
			ET541	S451522 - S457443
			ET581	S452313 - S457105
			EV541	S453235 - S473183
			EV581	S452114 - S473116
			RT541	S449776 - S457554
			RT581	S449772 - S457346
			RU541	S449764 - S451516
			RV541	S449790 - S473197
RV581	S449792 - S473167			

MODEL	WMI	MY	VDS	START - FINISH
TUNDRA	5TB	2008	BT541	S458128 - S465088
			BT581	S460039 - S463353
			BV541	S489753 - S524241
			BV581	S490994 - S524168
			DT541	S458232 - S465032
			DT581	S458211 - S465038
			DV541	S490988 - S524251
			DV581	S490274 - S524192
			ET541	S457566 - S461702
			ET581	S460063 - S460135
			EV541	S473215 - S483286
			EV581	S472420 - S483281
			RT541	S457555 - S461703
			RT581	S457567 - S459791
RV541	S473199 - S483282			
RV581	S473206 - S483264			

MODEL	WMI	MY	VDS	START - FINISH
TUNDRA	5TF	2007	BT541	X001509 - X010233
			BT581	X001504 - X009214
			BV541	X002493 - X032595
			BV581	X002480 - X032589
			CT541	X001009 - X002214
			CV541	X001185 - X005181
			DT541	X009296 - X009985
			DT581	X009401 - X009401
			DV541	X023882 - X032593
			DV581	X022843 - X032590
			ET541	X015154 - X016078
			ET581	X015222 - X015222
			EV541	X025255 - X032800
			EV581	X025031 - X032788
			JT521	X001258 - X002235
			JU521	X001130 - X003335
			JV521	X001122 - X002393
			KT521	X001022 - X002147
			KV521	X001133 - X002462
			LT521	X001572 - X016115
			LU521	X001203 - X006726
			LV521	X003495 - X032768
			MT521	X001506 - X010227
			MV521	X002485 - X032585
			RT541	X001571 - X016317
			RT581	X001570 - X016043
			RU541	X001200 - X006742
			RV541	X003586 - X032799
			RV581	X003587 - X032785
			ST541	X001106 - X002069
SV541	X001063 - X004748			

MODEL	WMI	MY	VDS	START - FINISH
TUNDRA	5TF	2008	BT541	X010234 - X014584
			BT581	X010659 - X013869
			BV541	X032597 - X083158
			BV581	X032603 - X083120
			CT541	X002218 - X002439
			CV541	X005183 - X008862
			DT541	X010580 - X013787
			DT581	X012554 - X012753
			DV541	X032596 - X083159
			DV581	X032602 - X083167
			ET541	X016320 - X027282
			ET581	X022981 - X026381
			EV541	X032809 - X069738
			EV581	X032801 - X069597
			JT521	X002236 - X002401
			JU521	X003336 - X004115
			JV521	X002395 - X003232
			KT521	X002148 - X002358
			KV521	X002463 - X003358
			LT521	X016321 - X027335
			LU521	X006748 - X017477
			LV521	X032804 - X069666
			MT521	X010235 - X014590
			MV521	X032626 - X083124
			RT541	X016318 - X027320
			RT581	X017618 - X020071
			RU541	X006743 - X017473
			RV541	X032802 - X069735
			RV581	X032846 - X069669
			ST541	X002070 - X002160
SV541	X004749 - X006281			

(Number of Vehicles Involved Continued. . .)

MODEL	WMI	MY	VDS	START - FINISH
TUNDRA	5TF	2009	BT541	X014611 - X015672
			BV541	X083229 - X094475
			BV581	X083255 - X092224
			BW541	X083226 - X094474
			BW581	X083224 - X094470
			CT541	X002440 - X002442
			CV541	X008872 - X009340
			CW541	X008870 - X009343
			DT541	X014616 - X015546
			DV541	X083242 - X094456
			DV581	X083244 - X094356
			DW541	X083227 - X094471
			DW581	X083217 - X094450
			ET541	X028344 - X028907
			EV541	X069830 - X073898
			EV581	X069778 - X073903
			JU521	X004131 - X004208
			JV521	X003234 - X003256
			KT521	X002362 - X002376
			KV521	X003364 - X003503
			KW521	X003384 - X003510
			LT521	X027997 - X029309
			LU521	X017497 - X020451
			LV521	X070510 - X073112
			MT521	X014876 - X015419
			MV521	X085497 - X094424
			MW521	X084767 - X094316
			RT541	X027383 - X029316
			RU541	X017498 - X020454
			RV541	X069772 - X073904
			RV581	X070033 - X073900
			ST541	X002171 - X002179
SV541	X006283 - X006375			

MODEL	WMI	MY	VDS	START - FINISH
TUNDRA	5TF	2010	BM5F1	X002356 - X008641
			BW5F1	X093050 - X129078
			BY5F1	X093061 - X129101
			CM5F1	X001001 - X001185
			CW5F1	X009335 - X010458
			CY5F1	X009336 - X010456
			DM5F1	X001019 - X009218
			DW5F1	X093128 - X129132
			DY5F1	X094480 - X129135
			EM5F1	X001006 - X012942
			EY5F1	X073303 - X088236
			FM5F1	X001806 - X012029
			FY5F1	X073300 - X088204
			HM5F1	X002336 - X008496
			HW5F1	X093038 - X129151
			HY5F1	X093142 - X129092
			JM5F1	X001002 - X001115
			JU5F1	X004209 - X004491
			JY5F1	X003257 - X003304
			KM5F1	X001001 - X001247
			KW5F1	X003513 - X004076
			KY5F1	X003514 - X004079
			LM5F1	X001026 - X012850
			LU5F1	X020324 - X022890
			LY5F1	X074019 - X087829
			MM5F1	X001020 - X009023
			MW5F1	X094824 - X128358
			MY5F1	X093123 - X127999
			RM5F1	X001008 - X012961
			RU5F1	X020455 - X022894
			RY5F1	X073343 - X088224
			SM5F1	X004749 - X012442
SY5F1	X073306 - X088151			
TM5F1	X001001 - X001152			
TY5F1	X006373 - X006786			
UM5F1	X001021 - X009228			
UW5F1	X093055 - X129131			
UY5F1	X094485 - X129140			

TUNDRA UIO: 426,000

5. Parts Ordering

The necessary parts can be ordered through your dealership’s facing PDC. Please refer to the table below and the Technical Instructions (located on TIS) for part number information.

To support the repair of customer vehicles the North American Parts Operation (NAPO) will initially allocate reinforcement bars to all Toyota dealerships from their facing parts distribution centers (PDC) starting February 3, 2010. All part numbers will be on manual allocation until further notice.

The initial quantities were determined based on the following:

- Size estimation required for the repair – Low/Medium/ High.
- Dealership’s estimated UIO by affected model.

Each dealership will be sent a minimum of one 10 piece bag for each of the reinforcement bar part numbers.

Any questions, request or concerns regarding the parameters established above should be directed to your regional representative.

Accelerator Pedal Reinforcement Bar

Model	Part Number	Part Name and Size	Repair Volume Estimate By Size
All Applicable Models	78112-07010*	Accelerator Pedal Reinforcement Bar Size: 1.4 mm	Low
	78112-07020*	Accelerator Pedal Reinforcement Bar Size: 1.6 mm	Low
	78112-07030*	Accelerator Pedal Reinforcement Bar Size: 1.8 mm	High
	78112-07040*	Accelerator Pedal Reinforcement Bar Size: 2.0 mm	High
	78112-07050*	Accelerator Pedal Reinforcement Bar Size: 2.3 mm	High
	78112-07060*	Accelerator Pedal Reinforcement Bar Size: 2.6 mm	Medium
	78112-07070*	Accelerator Pedal Reinforcement Bar Size: 2.9 mm	Medium

* One unit order = 10 piece bag.

NOTE: To determine the correct size of accelerator pedal reinforcement bar needed, refer to the Technical Instructions located on TIS.

To help ensure correct parts distribution, all part numbers listed above will be on manual allocation control (MAC) until further notice.

NAPO will place and release orders for the initial quantities to be allocated to each dealer over the first two weeks of the campaign (subject to change), and will cancel dealer initiated orders during this period.

If there are special circumstances, dealership associates should go through their normal channels for resolution (e.g. PDC, Dealer Parts Call Center for TMS Region Dealers, DSPMs).

The associate should have the following information ready to expedite research of the order status:

1. Dealer Information (Dealer Code, Contact Name, Telephone Number)
2. Order Reference Number
3. Customer Name and Vehicle 17-digit VIN (if applicable)

(Parts Ordering Continued. . .)

IMPORTANT PARTS ORDERING REMINDER

Effective March 1, 2009, Safety Recall, Service Campaign (SSC/LSC) and Customer Support Program (CSP) parts do not earn Parts Return Credit Accrual and are not returnable under the Monthly Return Program.

It is recommended that you order these parts based on appointments or immediate customer needs using a "Sell One-Buy One" ordering pattern. Please refer to PANT Bulletin 09-12 for additional details.

In the event the accelerator link arm support cover (thin metal cover on the back of the accelerator pedal) is damaged during the repair, please utilize the part number listed below.

Model	Part Number	Part Name	Qty/Unit
All Applicable Models	78211-07010	Accelerator Link Arm Support Cover	1

7. Repair Procedures

Refer to TIS for the appropriate Technical Instructions. Conduct all applicable, open Special Service Campaigns on the vehicle during the time of appointment.

8. Warranty Processor Instructions

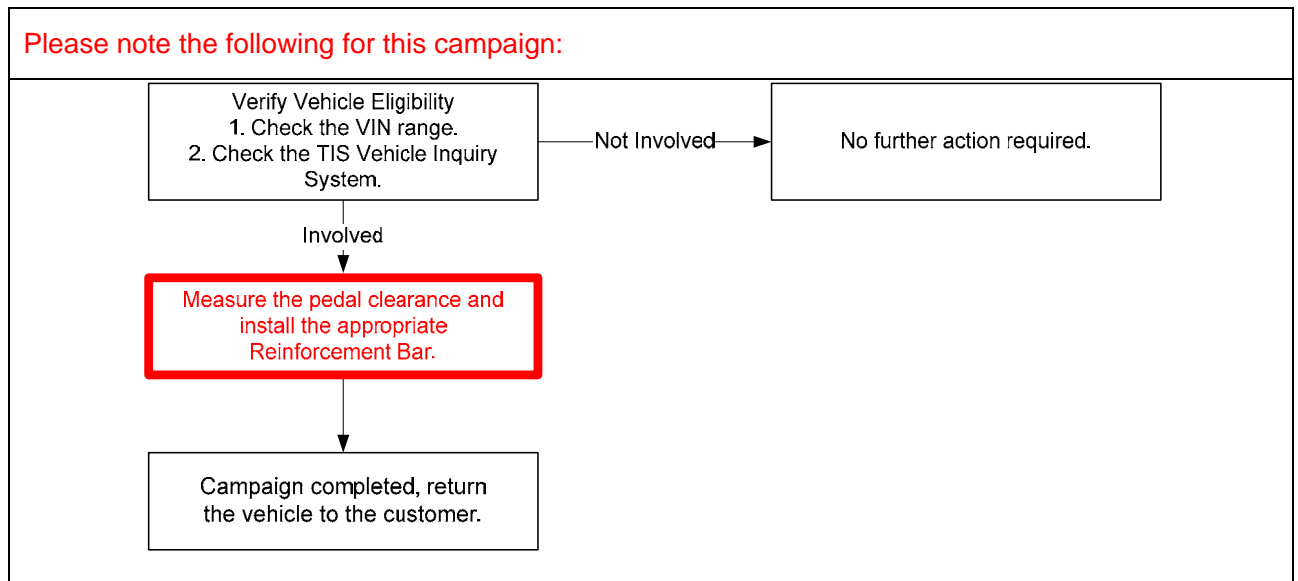

The operation codes to be used for this campaign are:

SSC	Op. Code	Description	Flat Rate Hour
A0A	0501B1	Install the Accelerator Pedal Reinforcement Bar	0.7 hr / vehicles
A0A	0501B2	Install the Accelerator Pedal Reinforcement Bar in conjunction with SSC 90L	0.4 hr / vehicles

- The above flat rate time includes 0.1 hour for administrative cost per unit.
- Rental Car: Use "RT" sublet type for Op. Code 0501B1 and 0501B2. Customer rental car through the Toyota-Rent-A-Car (TRAC) Program is available for a maximum of one day at a maximum rate of \$35 per day. Special accommodations, not outlined above require DSPM authorization.
- Claims made for Op Code 0501B1 or 0501B2 must be filled in with accurate part numbers (according to reinforcement bar thickness).

9. Customer Handling

Please consider this campaign a great opportunity to focus on assuring customers that their safety remains Toyota's highest priority. Customers who receive the owner letter may contact your dealership with questions regarding the letter and/or campaign remedy. Please welcome them to your dealership and answer any questions that they may have. A Q&A is provided to assure a consistent message is communicated.

- Customers with additional questions or concerns are asked to please contact the Toyota Customer Experience Center (1-888-270-9371).
- If an owner has previously paid for accelerator pedal repairs to address this specific condition, they are requested to mail a copy of the repair order, proof-of-payment, and proof-of-ownership to the following address for reimbursement consideration

Toyota Motor Sales, U.S.A., Inc
Toyota Customer Experience Center, WC10
19001 South Western Avenue
Torrance, CA 90509

7. Media Contacts

For ***News media inquiries only***:

Due to the nature of this Safety Campaign, it is imperative that all media contacts (local and national) receive a consistent message. In this regard, ***all media contacts*** must be directed to Brian Lyons (310) 468-2552, John Hanson (310) 468-4718, in Corporate Communications. (Please do not provide these numbers to customers or direct dealership associates to call).

Please review this entire package with your Service and Parts staff to familiarize them with the proper step-by-step procedures required to implement this Special Service Campaign.

Thank you for your cooperation.
TOYOTA MOTOR SALES, U.S.A., INC.

**Safety Recall A0A - (MODEL) Vehicles
Accelerator Pedal Reinforcement Bar Installation
SAFETY RECALL NOTICE**

Dear Toyota Customer:

This notice is being sent to you in accordance with the requirements of the National Traffic and Motor Vehicle Safety Act. Toyota has decided that a defect, which relates to motor vehicle safety, exists in (MY) model year (Model) vehicles.

What is the condition?

There is a possibility that certain accelerator pedal mechanisms may mechanically stick in a partially depressed position or return slowly to the idle position. Over time, the internal mechanisms in the accelerator pedal may become worn. As a result of this wear combined with certain operating and environmental conditions, friction in the mechanism may increase and intermittently result in the accelerator pedal being hard to depress and/or slow to return or, in the worst case, stick in a partially open position, increasing the risk of a crash.

What will Toyota do?

Any authorized Toyota dealer will install a precision-cut steel reinforcement bar into the accelerator pedal assembly, which will increase the clearance in between the internal mechanisms in the accelerator pedal assembly. This increased clearance will reduce the friction caused by wear and environmental conditions and allow the pedal to operate smoothly for the life of the vehicle. The safety recall remedy will be performed at **no charge** to the vehicle owner.

What should you do?

This is an important Safety Recall

Please contact your authorized Toyota dealer to install the precision-cut steel reinforcement bar into the accelerator pedal assembly as soon as possible. The installation will take approximately 30 minutes. However, depending upon the dealer's work schedule and the inspection results, it may be necessary for you to make your vehicle available for a longer period of time.

We request that you present this notice to the dealer at the time of your service appointment.

If you would like to update your vehicle ownership or contact information, please go to www.toyota.com/ownersupdate. You will need your full 17-digit Vehicle Identification Number (VIN) to input the new information.

What if you have other questions?

Your local Toyota dealer will be more than happy to answer any of your questions and set up an appointment to perform this important Safety Recall. If you require further assistance, you may contact the Toyota Customer Experience Center at 1-888-270-9371 Monday through Friday, 5:00 am to 6:00 pm, Saturday 7:00 am through 4:00 pm Pacific Time. Your satisfaction is extremely important to us. If you are not satisfied with the accelerator pedal operation or the feel of the pedal after the reinforcement bar has been installed, a replacement accelerator pedal will be offered at no charge when they become available.

If you believe that the dealer or Toyota has failed or is unable to remedy the defect within a reasonable time, you may submit a complaint to the Administrator, National Highway Traffic Safety Administration, 1200 New Jersey Avenue S.E., Washington, DC 20590 or call the toll free Vehicle Safety Hot Line at 1-888-327-4236 (TTY: 1-800-424-9153), or go to <http://www.safercar.gov>.

What if you have previously paid for your vehicle's accelerator pedal to be replaced to address the specific condition described above?

If you have previously paid for your vehicle's accelerator pedal to be replaced to address the specific condition described above, please mail a copy of your repair order, proof-of-payment, and proof-of-ownership to the following address for reimbursement consideration:

Toyota Motor Sales, U.S.A., Inc
Toyota Customer Experience, WC10
19001 South Western Avenue
Torrance, CA 90509

If you are a vehicle lessor, Federal law requires that any vehicle lessor receiving this recall notice must forward a copy of this notice to the lessee within ten days.

We have sent this notice in the interest of your continued satisfaction with our products and we sincerely regret any inconvenience this condition may have caused you.

Thank you for driving a Toyota.

Sincerely,

TOYOTA MOTOR SALES, U.S.A., INC.

Sample



Safety Recall A0A - Accelerator Pedal Reinforcement Bar Installation Q&A

Q1: What is the condition?

A1: There is a possibility that certain accelerator pedal mechanisms may mechanically stick in a partially depressed position or return slowly to the idle position.

Q2: What is the cause of this condition?

A2: Over time, the internal mechanisms in the accelerator pedal may become worn. As a result of this wear combined with certain operating and environmental conditions, friction in the mechanism may increase and intermittently result in the accelerator pedal being hard to depress and/or slow to return or, in the worst case, stick in a partially open position, increasing the risk of a crash.

Q2a: Why does this condition only affect certain Toyota models?

A2a: Toyota equips its vehicles with accelerator pedals manufactured by multiple suppliers. Only vehicles equipped with accelerator pedals produced by a specific supplier are affected.

Q3: Are there any warnings that this condition exists?

A3: Gradually over a period of time, the driver may notice that the accelerator pedal is harder to depress or is slow to return. In some cases, the driver may notice a rough or chattered feeling when depressing/releasing the accelerator pedal.

Q4: Which and how many vehicles are involved?

A4: There are approximately 2.23 million vehicles involved in the U.S.

Model Year	Model	Approx UIO
2005 - 2010	Avalon	330,000
2007 - 2010	Camry*	786,000
2009 - 2010	Corolla	490,000
2010	Highlander*	20,000
2009 - 2010	Matrix	75,000
2009 - 2010	RAV4	53,000
2008 - 2010	Sequoia	50,000
2007 - 2010	Tundra	426,000

*Camry Hybrid and Highlander Hybrid vehicles are equipped with an accelerator pedal that is of a different design and produced by a different supplier. Therefore, it does not require the installation of the reinforcement bar.

Q4a: What is the cost of this Safety Recall?

A4a: Toyota does not release cost information regarding its programs.

Q4b: Why are some vehicles that fall within the model and model year listed above not affected?

A4b: Toyota has isolated this condition to a specific supplier. Multiple suppliers may be utilized to furnish the accelerator pedal on a given model.

Q5: Are there any other Toyota or Lexus vehicles involved?

A5: No, this specific condition only affects the above vehicles.

Q6: How many incidents of this condition have been reported?

A6: The number of incidents is still under investigation.

Q7: Have there been any accidents reported?

A7: The number of accidents is still under investigation.

Q8: What is Toyota going to do?

A8: Any Toyota dealer will install a reinforcement bar that will increase the clearance in-between the internal mechanisms in the accelerator pedal assembly. This increased clearance will reduce the friction caused by wear and environmental conditions and allow the pedal to operate smoothly for the life of the vehicle. The campaign remedy will be performed at **no charge** to the vehicle owner.

Q8a: How will the accelerator pedal feel once the accelerator reinforcement plate is installed?

A8a: Customers will not notice a difference in the feel of the accelerator pedal. Any local Toyota dealer will be more than happy to go over the entire repair with the customer.

Q8b: What if a customer is not satisfied with the accelerator pedal operation or the feel of the pedal after the reinforcement plate is installed?

Q8b: If the customer is not satisfied with the accelerator pedal operation or the feel of the pedal after the reinforcement bar has been installed, a replacement accelerator pedal will be offered at no charge when they become available.

Q8c: When will the remedy for floor mat interference with the accelerator pedal be available?

Q8c: Toyota has developed the remedy for floor mat interference with the accelerator on the following vehicles (Refer to SSC 90L Phase 1 and Phase 2 for additional details):

- 2007 – 2010 Camry & Camry Hybrid

Toyota is currently in the process of developing a remedy for floor mat interference with the accelerator pedal on the following models and will notify owners as soon as it is available.

- 2005 – 2010 Avalon
- 2009 – 2010 Corolla
- 2008 – 2010 Highlander & Highlander Hybrid
- 2009 – 2010 Matrix
- 2004 – 2009 Prius
- 2005 – 2010 Tacoma
- 2007 – 2010 Tundra
- 2009 – 2010 Venza

Lexus has developed and launched the remedy for 2007 – 2010 ES. Lexus is currently developing a remedy for the 2006 – 2010 IS.

It is important to note that the floor mat interference with the accelerator pedal campaign is separate and independent from the accelerator pedal reinforcement campaign.

Q9: How long will the repair take?

A9: The remedy will take approximately 30 minutes. However, depending upon the dealer's work schedule, it may be necessary to make the vehicle available for a longer period of time.

Q10: What should customers do if his/her vehicle is involved in this campaign but so far, have not experienced this condition?

A10: This condition is rare. However, if you have any concerns please contact your nearest Toyota Dealer for assistance.

Q11: What if the customer has noticed that his/her accelerator pedal is hard to depress, slow to return or is unsmooth during operation. What should he/she do?

A11: The customer is requested to immediately contact his/her nearest Toyota Dealer for assistance. The Toyota dealer will evaluate the customer's complaint.

Q12: What if the customer experiences a sticking accelerator pedal while driving?

A12: Each circumstance may vary, and drivers must use their best judgment, but Toyota is providing the following instructions.

- If you need to stop immediately, the vehicle can be controlled by stepping on the brake pedal with both feet using firm and steady pressure. Do not pump the brake pedal as it will deplete the vacuum utilized for the power brake assist.
- Shift the transmission gear selector to the Neutral (N) position and use the brakes to make a controlled stop at the side of the road and turn off the engine.
- If unable to put the vehicle in Neutral, turn the engine OFF. This will not cause loss of steering or braking control, but the power assist to these systems will be lost.
 - If the vehicle is equipped with an Engine Start/Stop button, firmly and steadily push the button for at least three seconds to turn off the engine. Do NOT tap the Engine Start/Stop button.
 - If the vehicle is equipped with a conventional key-ignition, turn the ignition key to the ACC position to turn off the engine. Do NOT remove the key from the ignition as this will lock the steering wheel.

In the event that a driver experiences an accelerator pedal that sticks in a partial open throttle position or returns slowly to idle position, the vehicle can be controlled with firm and steady application of the brakes. The brakes should not be pumped repeatedly because it could deplete vacuum assist, requiring stronger brake pedal pressure. The vehicle should be driven to the nearest safe location, the engine shut off and a Toyota dealer contacted for assistance.

Q13: What if a customer has previously paid for repairs to address the same condition described above?

A13: Owners that have previously paid for accelerator pedal repairs to address the same condition described above, the customer should mail a copy of his/her repair order, proof-of-payment, and proof-of-ownership to the following address for reimbursement consideration

Toyota Motor Sales, U.S.A., Inc
Toyota Customer Experience, WC10
19001 South Western Avenue
Torrance, CA 90509

Q14: What should an owner do if they have immediate concerns about their vehicle?

A14: If an owner has any immediate concerns they are requested to contact their local Toyota dealer for diagnosis, and if applicable, necessary repair. Owners may also contact the Toyota Customer Experience Center (1-800-331-4331).

TECHNICAL INSTRUCTIONS
FOR
SAFETY RECALL A0A
CTS ACCELERATOR PEDAL
REINFORCEMENT BAR INSTALLATION

2005 – 2010 Model Year Avalon
2007 – 2010 Model Year Camry
2009 – 2010 Model Year Corolla
2010 Model Year Highlander
2009 – 2010 Model Year Matrix
2009 – 2010 Model Year Rav4
2008 – 2010 Model Year Sequoia
2007 – 2010 Model Year Tundra

REVISED FEBRUARY 5, 2010

TECHNICAL INSTRUCTION REVISION NOTICE:

- **February 4, 2010:**
 - VIN range was updated for 2010 Corolla.
 - Negative battery cable disconnect procedure now applies to all models.
 - A note was added to Work Procedure step 3, "PUMP ACCELERATOR PEDAL ASSEMBLY".
 - A revised picture has been added to reinforce using the "ALL DATA" function while checking Techstream Data List Parameters on step 14.
- **February 5, 2010:**
 - VIN range was updated for 2010 Camry.
 - An additional step was added to Work Procedure step 11 "REINSTALL THE ACCELERATOR PEDAL ASSEMBLY".

Previous versions of this Technical Instruction should be discarded.

I. OPERATION FLOW CHART

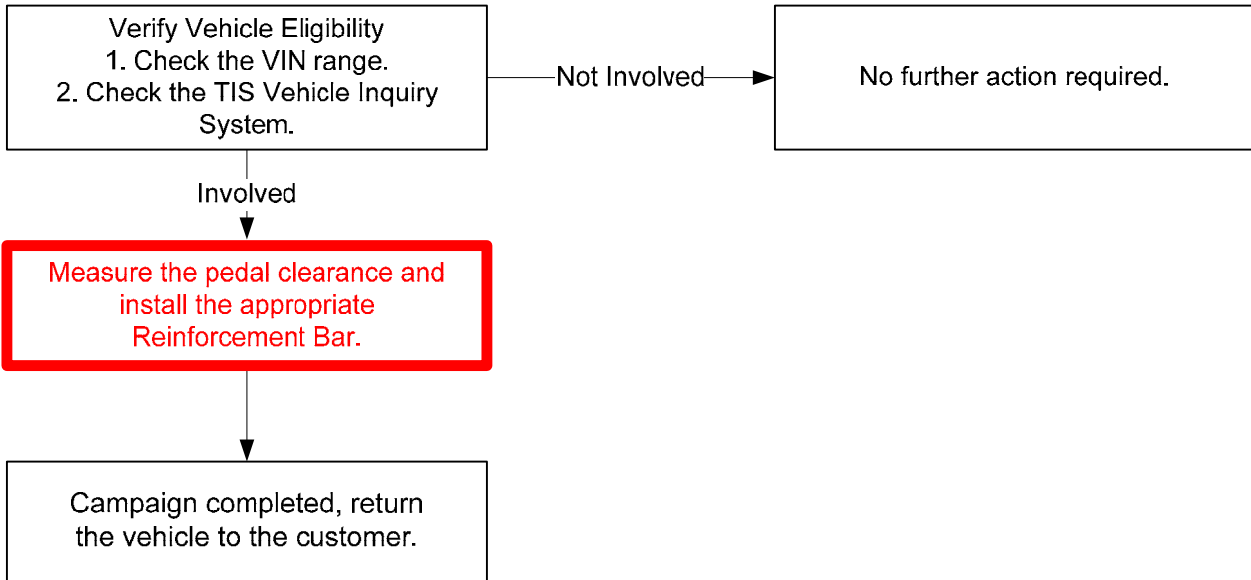

II. IDENTIFICATION OF AFFECTED VEHICLES

A. AFFECTED VIN RANGE

MODEL	WMI	MY	VDS	START - FINISH
AVALON	4T1	2005	BK36B	U001003 - U062426
		2006	BK36B	U042154 - U167717
		2007	BK36B	U149048 - U253880
		2008	BK36B	U209130 - U324241
		2009	BK36B	U305357 - U351925
		2010	BK3DB	U351302 - U367444

AVALON UIO: 330,000

MODEL	WMI	MY	VDS	START - FINISH
COROLLA	1NX	2009	BE40E	Z001001 - Z163790
			BU40E	Z001002 - Z165305
		2010	BE4EE	Z165306 - Z333282
			BU4EE	Z165312 - Z337444
	2T1	2009	BE40E	C001043 - C030479
			BU40E	C001054 - C191051
		2010	BE4EE	C030504 - C039875
			BU4EE	C185955 - C348040

COROLLA UIO: 490,000

MODEL	WMI	MY	VDS	START - FINISH	
CAMRY*	4T1	2007	BE46K	U001001 - U195222	
			U504376 - U729526		
		2008	BK46K	U001003 - U054581	
			BE46K	U171709 - U263248	
			U730123 - U791444		
			BK46K	U040415 - U073251	
		2009	BE46K	U260017 - U416640	
			BK46K	U073252 - U098189	
		2010	BF3EK	U001001 - U112408	
			BK3EK	U091136 - U116164	
		4T4	2007	BE46K	R001003 - R011624
			2008	BE46K	R001816 - R047779
2009	BE46K		R027105 - R139848		
2010	BF3EK		R001023 - R085180		

CAMRY UIO: 786,000

**Camry Hybrid vehicles are equipped with an accelerator pedal that is of a different design and produced by a different supplier. Therefore, it does not require the installation of an accelerator pedal reinforcement bar.*

MODEL	WMI	MY	VDS	START - FINISH
HIGHLANDER*	5TD	2010	BK3EH	S001052 - S013868
			DK3EH	S001067 - S013863
			EK3EH	S001051 - S008434
			JK3EH	S005002 - S013869
			KK3EH	S003272 - S008683
			XK3EH	S001026 - S005688
			YK3EH	S001030 - S008686
			ZA3EH	S001019 - S003107
ZK3EH	S001020 - S008685			

HIGHLANDER UIO: 20,000

*Highlander Hybrid vehicles are equipped with an accelerator pedal that is of a different design and produced by a different supplier. Therefore, it does not require the installation of an accelerator pedal reinforcement bar.

MODEL	WMI	MY	VDS	START - FINISH
SEQUOIA	5TD	2008	BT64A	S000014 - S000239
			BY64A	S000047 - S023603
			BY67A	S000042 - S023596
			BY68A	S000034 - S023597
			ZT64A	S000014 - S000384
			ZY64A	S000010 - S015402
			ZY67A	S000012 - S015400
			ZY68A	S000013 - S015401
		2009	BT64A	S000244 - S001152
			BW68A	S023606 - S023606
			BY64A	S023711 - S023868
			BY67A	S023609 - S023857
			BY68A	S023616 - S023856
			ZT64A	S000438 - S000953
			ZY64A	S019566 - S020863
			ZY67A	S015919 - S015919
		ZY68A	S015426 - S021051	
		2010	BM5G1	S001002 - S001225
			BW5G1	S023880 - S032694
			BY5G1	S023869 - S032719
			DW5G1	S023878 - S032718
			DY5G1	S023870 - S032709
			JW5G1	S023876 - S032713
			JY5G1	S023871 - S032708
			KM5G1	S001417 - S001458
			KY5G1	S022514 - S027553
			YY5G1	S022511 - S027563
			ZM5G1	S001034 - S002051
			ZY5G1	S022519 - S027561
			ZY67A	S020526 - S020527

SEQUOIA UIO: 50,000

MODEL	WMI	MY	VDS	START - FINISH
MATRIX	2T1	2009	GE40E	C001023 - C005748
			KE40E	C001042 - C030591
			KU40E	C001057 - C191049
			LE40E	C001017 - C011935
		2010	KE4EE	C030606 - C039888
			KU4EE	C191054 - C348047
			LE4EE	C011822 - C016115
			ME4EE	C005690 - C006299

MATRIX UIO: 75,000

MODEL	WMI	MY	VDS	START - FINISH
RAV4	2T3	2009	BF31V	W001119 - W024119
			BF32V	W001207 - W024120
			BF33V	W001117 - W024117
			BF34V	W003775 - W021681
			BF35V	W001421 - W024111
			BK31V	W001143 - W013774
			BK32V	W001142 - W013693
			BK33V	W001162 - W013773
			BK34V	W001688 - W010762
			BK35V	W002139 - W013749
			ZF31V	W001050 - W016880
			ZF32V	W001048 - W016874
			ZF33V	W001049 - W016918
			ZF34V	W003810 - W012950
			ZF35V	W001625 - W016916
			ZK31V	W001081 - W003645
			ZK32V	W001149 - W003642
			ZK33V	W001076 - W003644
			ZK34V	W001670 - W002621
			ZK35V	W001965 - W003631
		2010	BF4DV	W022899 - W038726
			BK4DV	W013775 - W020737
			DF4DV	W024130 - W038723
			DK4DV	W013776 - W020732
			EF4DV	W024745 - W035186
			EK4DV	W014634 - W020625
			JF4DV	W024129 - W038700
			JK4DV	W013811 - W020629
			KF4DV	W016950 - W027204
			KK4DV	W003824 - W005660
			RF4DV	W022777 - W038716
			RK4DV	W013813 - W020685
			WF4DV	W016936 - W027202
			WK4DV	W003659 - W005669
			XF4DV	W018112 - W025585
			XK4DV	W003701 - W005572
			YF4DV	W016920 - W027201
			YK4DV	W003435 - W005673
			ZF4DV	W016923 - W027211
			ZK4DV	W003652 - W005662

RAV4 UIO: 53,000

MODEL	WMI	MY	VDS	START - FINISH
TUNDRA	5TB	2007	BT541	S449772 - S458203
			BT581	S449768 - S458119
			BV541	S449818 - S490980
			BV581	S449815 - S490940
			DT541	S452172 - S458112
			DT581	S451402 - S457120
			DV541	S454929 - S490979
			DV581	S454922 - S490970
			ET541	S451522 - S457443
			ET581	S452313 - S457105
			EV541	S453235 - S473183
			EV581	S452114 - S473116
			RT541	S449776 - S457554
			RT581	S449772 - S457346
			RU541	S449764 - S451516
			RV541	S449790 - S473197
RV581	S449792 - S473167			

MODEL	WMI	MY	VDS	START - FINISH
TUNDRA	5TB	2008	BT541	S458128 - S465088
			BT581	S460039 - S463353
			BV541	S489753 - S524241
			BV581	S490994 - S524168
			DT541	S458232 - S465032
			DT581	S458211 - S465038
			DV541	S490988 - S524251
			DV581	S490274 - S524192
			ET541	S457566 - S461702
			ET581	S460063 - S460135
			EV541	S473215 - S483286
			EV581	S472420 - S483281
			RT541	S457555 - S461703
			RT581	S457567 - S459791
			RV541	S473199 - S483282
			RV581	S473206 - S483264

MODEL	WMI	MY	VDS	START - FINISH
TUNDRA	5TF	2007	BT541	X001509 - X010233
			BT581	X001504 - X009214
			BV541	X002493 - X032595
			BV581	X002480 - X032589
			CT541	X001009 - X002214
			CV541	X001185 - X005181
			DT541	X009296 - X009985
			DT581	X009401 - X009401
			DV541	X023882 - X032593
			DV581	X022843 - X032590
			ET541	X015154 - X016078
			ET581	X015222 - X015222
			EV541	X025255 - X032800
			EV581	X025031 - X032788
			JT521	X001258 - X002235
			JU521	X001130 - X003335
			JV521	X001122 - X002393
			KT521	X001022 - X002147
			KV521	X001133 - X002462
			LT521	X001572 - X016115
			LU521	X001203 - X006726
			LV521	X003495 - X032768
			MT521	X001506 - X010227
			MV521	X002485 - X032585
			RT541	X001571 - X016317
			RT581	X001570 - X016043
			RU541	X001200 - X006742
			RV541	X003586 - X032799
			RV581	X003587 - X032785
			ST541	X001106 - X002069
			SV541	X001063 - X004748

MODEL	WMI	MY	VDS	START - FINISH
TUNDRA	5TF	2008	BT541	X010234 - X014584
			BT581	X010659 - X013869
			BV541	X032597 - X083158
			BV581	X032603 - X083120
			CT541	X002218 - X002439
			CV541	X005183 - X008862
			DT541	X010580 - X013787
			DT581	X012554 - X012753
			DV541	X032596 - X083159
			DV581	X032602 - X083167
			ET541	X016320 - X027282
			ET581	X022981 - X026381
			EV541	X032809 - X069738
			EV581	X032801 - X069597
			JT521	X002236 - X002401
			JU521	X003336 - X004115
			JV521	X002395 - X003232
			KT521	X002148 - X002358
			KV521	X002463 - X003358
			LT521	X016321 - X027335
			LU521	X006748 - X017477
			LV521	X032804 - X069666
			MT521	X010235 - X014590
			MV521	X032626 - X083124
			RT541	X016318 - X027320
			RT581	X017618 - X020071
			RU541	X006743 - X017473
			RV541	X032802 - X069735
			RV581	X032846 - X069669
			ST541	X002070 - X002160
			SV541	X004749 - X006281

MODEL	WMI	MY	VDS	START - FINISH
TUNDRA	5TF	2009	BT541	X014611 - X015672
			BV541	X083229 - X094475
			BV581	X083255 - X092224
			BW541	X083226 - X094474
			BW581	X083224 - X094470
			CT541	X002440 - X002442
			CV541	X008872 - X009340
			CW541	X008870 - X009343
			DT541	X014616 - X015546
			DV541	X083242 - X094456
			DV581	X083244 - X094356
			DW541	X083227 - X094471
			DW581	X083217 - X094450
			ET541	X028344 - X028907
			EV541	X069830 - X073898
			EV581	X069778 - X073903
			JU521	X004131 - X004208
			JV521	X003234 - X003256
			KT521	X002362 - X002376
			KV521	X003364 - X003503
			KW521	X003384 - X003510
			LT521	X027997 - X029309
			LU521	X017497 - X020451
			LV521	X070510 - X073112
			MT521	X014876 - X015419
			MV521	X085497 - X094424
			MW521	X084767 - X094316
			RT541	X027383 - X029316
			RU541	X017498 - X020454
			RV541	X069772 - X073904
			RV581	X070033 - X073900
			ST541	X002171 - X002179
SV541	X006283 - X006375			

MODEL	WMI	MY	VDS	START - FINISH
TUNDRA	5TF	2010	BM5F1	X002356 - X008641
			BW5F1	X093050 - X129078
			BY5F1	X093061 - X129101
			CM5F1	X001001 - X001185
			CW5F1	X009335 - X010458
			CY5F1	X009336 - X010456
			DM5F1	X001019 - X009218
			DW5F1	X093128 - X129132
			DY5F1	X094480 - X129135
			EM5F1	X001006 - X012942
			EY5F1	X073303 - X088236
			FM5F1	X001806 - X012029
			FY5F1	X073300 - X088204
			HM5F1	X002336 - X008496
			HW5F1	X093038 - X129151
			HY5F1	X093142 - X129092
			JM5F1	X001002 - X001115
			JU5F1	X004209 - X004491
			JY5F1	X003257 - X003304
			KM5F1	X001001 - X001247
			KW5F1	X003513 - X004076
			KY5F1	X003514 - X004079
			LM5F1	X001026 - X012850
			LU5F1	X020324 - X022890
			LY5F1	X074019 - X087829
			MM5F1	X001020 - X009023
			MW5F1	X094824 - X128358
			MY5F1	X093123 - X127999
			RM5F1	X001008 - X012961
			RU5F1	X020455 - X022894
			RY5F1	X073343 - X088224
			SM5F1	X004749 - X012442
SY5F1	X073306 - X088151			
TM5F1	X001001 - X001152			
TY5F1	X006373 - X006786			
UM5F1	X001021 - X009228			
UW5F1	X093055 - X129131			
UY5F1	X094485 - X129140			

TUNDRA UIO: 426,000

NOTE:

- Check the TIS Vehicle Inquiry System to confirm the VIN is involved in this Safety Recall, and that the campaign has not already been completed prior to dealer shipment or by another dealer.
- TMS warranty will not reimburse dealers for repairs conducted on vehicles that are not affected or were completed by another dealer.

III. PREPARATION

A. PARTS

Reinforcement Bar*			
Part Number	Thickness	Dealer QUP	Estimated Repair Volume
78112-07010	1.4	1 bag (10pcs)	Low
78112-07020	1.6	1 bag (10pcs)	Low
78112-07030	1.8	1 bag (10pcs)	High
78112-07040	2.0	1 bag (10pcs)	High
78112-07050	2.3	1 bag (10pcs)	High
78112-07060	2.6	1 bag (10pcs)	Medium
78112-07070	2.9	1 bag (10pcs)	Medium

*Dealerships will be sent a minimum of 1 bag of each of the 7 Reinforcement Bar part numbers.

**Only 1 Reinforcement bar is used per vehicle.

B. TOOLS & MATERIALS

- Standard hand tools
- Torque wrench
- Tape (electrical, masking)
- Metric Feeler Gauge

IV. BACKGROUND

There is a possibility that certain accelerator pedal mechanisms may, in rare instances, mechanically stick in a partially depressed position or return slowly to the idle position.

Over time, some accelerator pedal mechanisms may become worn. As a result of this wear combined with certain operating and environmental conditions, friction in the mechanism may increase and intermittently result in the accelerator pedal being hard to depress, slow to return or, in the worst case, stick in a partially open position.

V. WORK PROCEDURE



ACCELERATOR PEDAL HANDLING NOTES:

- **DO NOT drop: DO NOT reuse an accelerator pedal that has been dropped.**
- **Avoid vibration and shock.**

[CLICK HERE TO WATCH THE VIDEO BEFORE BEGINNING THE WORK PROCEDURE](#)

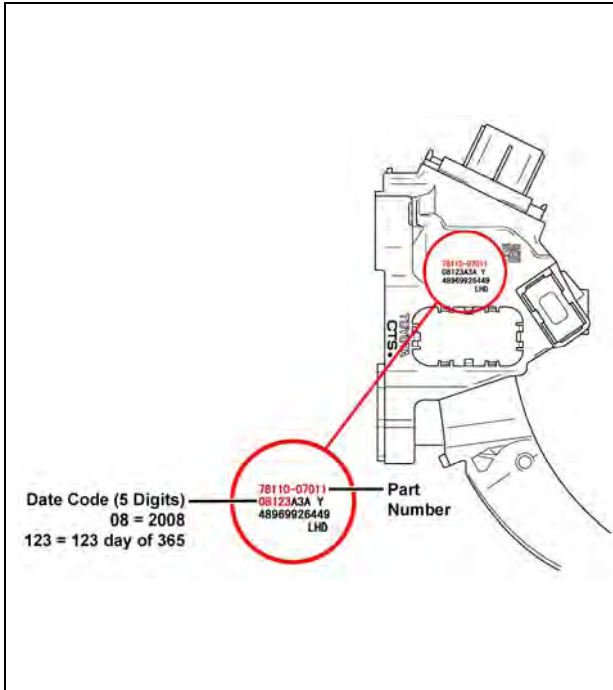

1. CONFIRM ACCELERATOR PEDAL PART NUMBER AND MANUFACTURE DATE CODE

- Verify the part number and manufacture date code according to the information found on the pedal.

Applicable Part Numbers	OK Date Code
78110-0C011	10018 & Later
78110-0R020	10018 & Later
78110-07011	10016 & Later
78110-08010	10015 & Later
78110-0C010	All NG
78110-07010	All NG

For OK Date Code:

- Vehicle is not involved, no further action required.
- Return vehicle to customer.

For NG Date Code:

- If the date code is a - smaller number/earlier date - than what is listed on the table above: Continue with these Technical Instructions.

2. DISCONNECT THE NEGATIVE BATTERY CABLE - ALL MODELS

- Record radio station presets.
- To prevent airbag and seat belt pretensioner activation on the following models, disconnect the negative battery cable and wait 90 seconds.

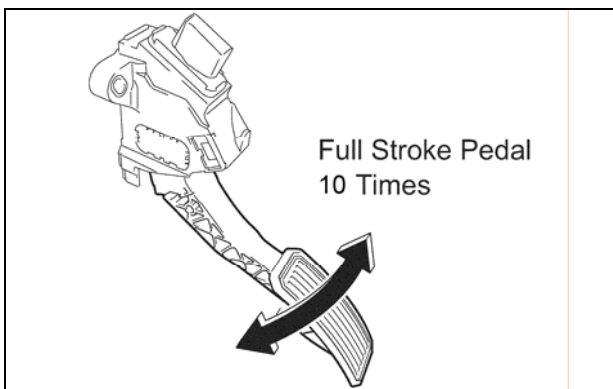

3. PUMP ACCELERATOR PEDAL ASSEMBLY

- Pump the accelerator pedal at least 10 times in a full stroke.

NOTE:

This step is to ensure an accurate measurement when checking the clearance between the stopper and the housing.

4. REMOVE THE ACCELERATOR PEDAL ASSEMBLY

- Disconnect the accelerator pedal electrical connector.
- Remove the 2 bolts OR 2 nuts depending on model.

NOTE: For additional information on accelerator pedal removal, please refer to TIS.

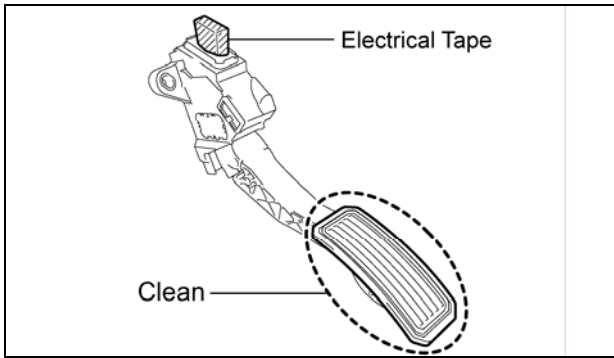

5. PROTECT CONNECTOR

[Click here to watch the video to supplement steps \(5-6\)](#)

- Tape the electrical connector using UL listed electrical tape.
- Clean the area indicated.

NOTE:

Do not use compressed air to clean; this may force dirt and debris into the sensor area.

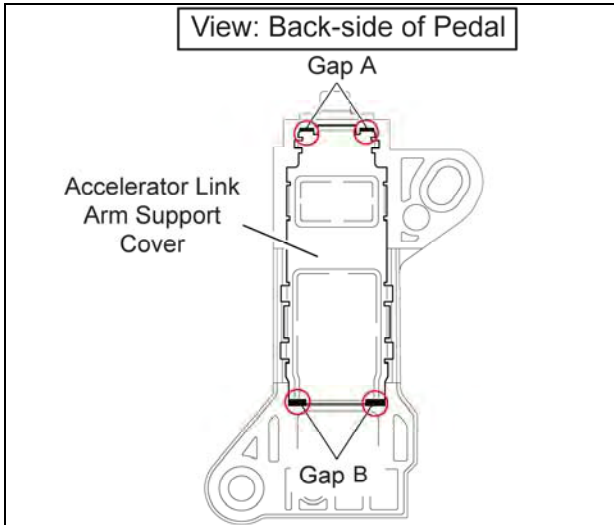

6. REMOVE THE ACCELERATOR LINK ARM SUPPORT COVER

NOTE:

Do not twist or bend the cover; it will need to be reinstalled.

- Using a pocket screwdriver, evenly and lightly pry up on **gaps (A)** and then **gaps (B)** to remove the cover.

NOTE:

Do not clean out any debris caused by wear; this may force the debris into gaps.

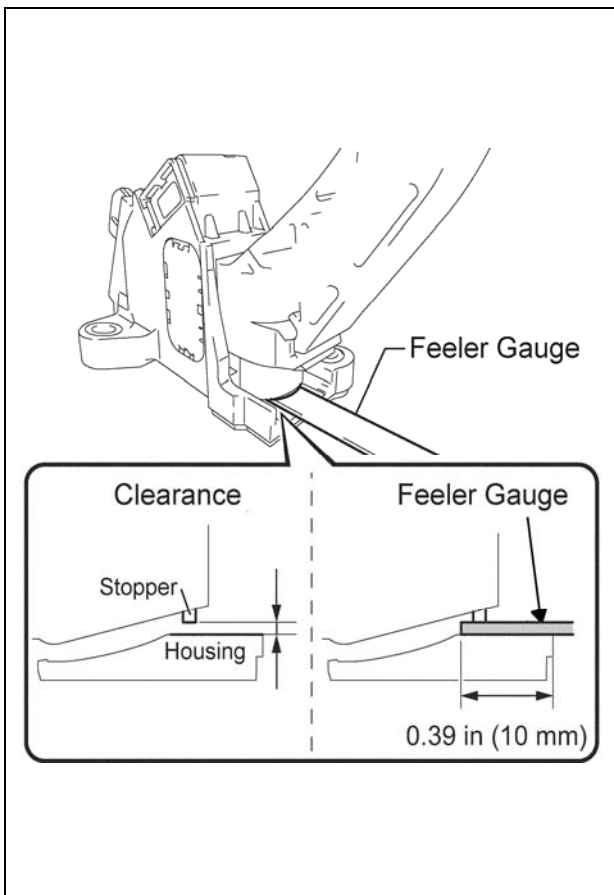

7. DETERMINE THE REINFORCEMENT BAR THICKNESS

[Click here to watch the video to supplement steps \(7-10\)](#)

- Using a feeler gauge, measure the clearance between the stopper and the housing.
- Only insert the feeler gauge 10mm from the end of the housing as illustrated.

NOTE:

Mark the feeler gauge 10mm from the edge to aid in measurement.

- Based on the measurement from step a), select the correct Reinforcement Bar using the table below.

Clearance	Reinforcement Bar	
	Thickness	Stamping
0.0 mm – 0.29 mm	1.4 mm	1.4 A
0.3 mm – 0.59 mm	1.6 mm	1.6 B
0.6 mm – 0.79 mm	1.8 mm	1.8 C
0.8 mm – 1.09 mm	2.0 mm	2.0 D
1.1 mm – 1.49 mm	2.3 mm	2.3 E
1.5 mm – 1.89 mm	2.6 mm	2.6 F
1.9 mm – 2.30 mm*	2.9 mm	2.9 G

***NOTE: Dealer in-stock and lower mileage vehicles may have a clearance greater than 2.3 mm and less than 2.7 mm. The 2.9 mm thickness reinforcement bar is specified for these cases.**

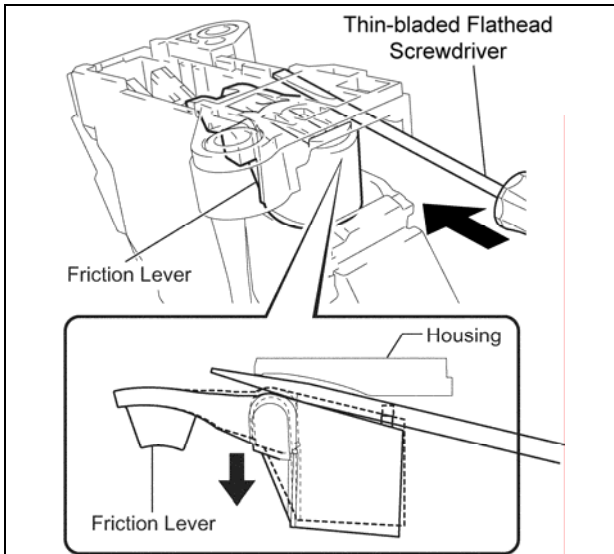

8. INSTALL REINFORCEMENT BAR

- a) Insert a clean thin-bladed flathead screwdriver between the housing and the friction lever until the friction lever lowers.

NOTE:

Do not push more than necessary; it may deform the housing.

NOTE:

Never stack multiple reinforcement bars inside of the pedal assembly.

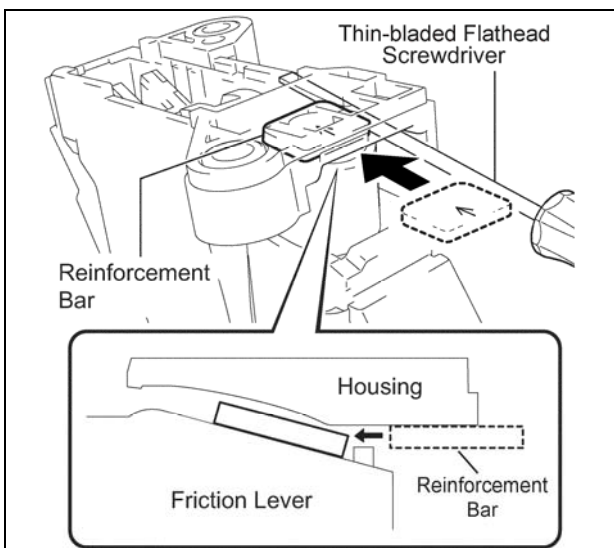

- b) With the increased clearance between the friction lever and the housing, insert the reinforcement bar selected from step 7.

NOTE:

- **Do NOT add any lubricants or chemicals to assist with installation!!**
- **As illustrated, insert the reinforcement bar with its stamped arrow facing up.**

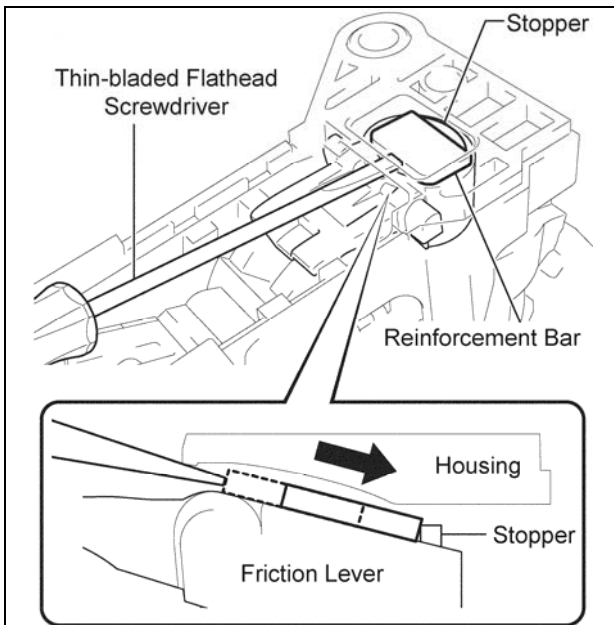
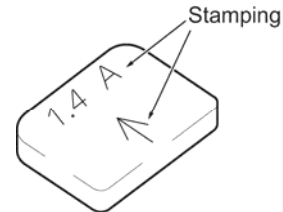

- c) From the back of the pedal, firmly push the reinforcement bar until it contacts the stopper.
 d) Carefully center the reinforcement bar behind the stopper using a pocket screwdriver.

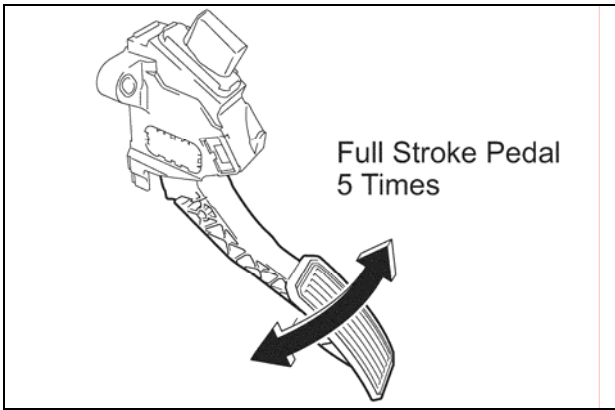

- e) Pump the accelerator pedal 5 times in a full stroke to properly seat the reinforcement bar.

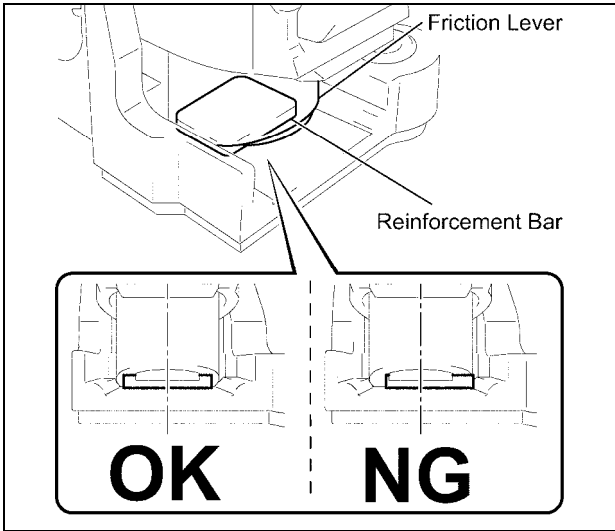

9. VERIFY REINFORCEMENT BAR INSTALLATION

- a) Verify that the reinforcement bar is properly centered and flush with the stopper.

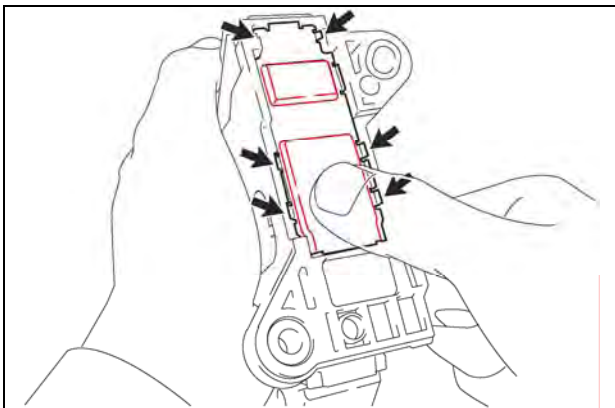

10. INSTALL THE ACCELERATOR LINK ARM SUPPORT COVER

- a) Repair any bent claws on the accelerator link arm support cover.
- b) With the two protrusions (illustrated in red) facing out, press down on the 6 claws to firmly install the accelerator link arm support cover.

NOTE:
If the cover is difficult to reinstall it may be installed upside down.

11. REINSTALL THE ACCELERATOR PEDAL ASSEMBLY

[Click here to watch the video to supplement steps \(11-15\)](#)

- a) Remove the tape from the electrical connector.
- b) Reinstall the pedal with the 2 bolts OR 2 nuts depending on model.
- c) Torque to specification.

Model	Torque Specification:	Model	Torque Specification:
Avalon	5.4 Nm (55 kgf cm, 48 in. lbf)	Corolla	5.5 Nm (56 kgf cm, 49 in. lbf)
Camry		Matrix	
RAV4		Sequoia	
Highlander		Tundra	5.0 Nm (51 kgf cm, 44 in. lbf)

- d) Reconnect the accelerator pedal connector.
- e) Reconnect the negative battery cable.
- f) Set the clock and radio station presets.
- g) Reinitialize the vehicle system(s) as outlined in the repair manual on TIS for the vehicle you are working on.

NOTE: For additional information on accelerator pedal installation, please refer to TIS.

12. CONFIRM THE CORRECT FLOOR MAT

- a) Confirm the correct floor mat for this model is secured with the retaining hooks (clips).
 - If the grommets in the floor for the vehicle are in poor condition, refer to the appropriate TSB and repair the grommets.

13. CHECK FOR DTC CODES

- a) Connect the Techstream to the DLC3.
- b) Check for DTC codes.

NOTE: If DTC(s) are displayed, verify the code(s) and record the freeze frame data, then perform repairs as necessary.

14. INSPECT THE ACCELERATOR PEDAL ASSEMBLY OPERATION

- a) Enter the following menus: Powertrain / Engine and ECT / Data List.

NOTE:

- There are two sets of the same Accel Sensor Out No. 1 & No. 2 parameters.
- Select ALL DATA on the pull down menu at the bottom of the screen when searching for the correct parameters.
- Do not use confuse these parameters with Throttle Position No.1 & 2.

The screenshot shows the Techstream software interface for a 2007 Camry. The 'Engine and ECT Live' menu is selected, displaying a list of parameters and their values. A red box highlights the 'All Data' dropdown menu at the bottom of the screen, and a red arrow points to it from the bottom of the screen.

Parameter	Value	Unit	Parameter	Value	Unit
Vehicle Speed	0	MPH	Throttle Require Position	4.0	V
Engine Speed	0	rpm	Throttle Sensor Position	65.0	%
Calculate Load	0.0	%	Throttle Position No. 1	0.000	V
Vehicle Load	0.0	%	Throttle Position No. 2	0.000	V
MAF	0.40	gm/sec	Throttle Position No. 1	4.0	V
Atmosphere Pressure	-0	psi(gauge)	Throttle Position No. 2	4.9	V
Coolant Temp	68	F	Throttle Position Command	4.0	V
Intake Air	82	F	Throttle Sens Open Pos #1	0.9	V
Engine Run Time	0	s	Throttle Sens Open Pos #2	2.0	V
Initial Engine Coolant Temp	68.0	F	Throttle Sens Open #1(AD)	4.0	V
Initial Intake Air Temp	83.7	F	Throttle Motor	ON	
Battery Voltage	11.8	V	Throttle Motor Current	0.8	A
Accel Sens. No. 1 Volt %	73.7	%	Throttle Motor DUTY	80.7	%
Accel Sens. No. 2 Volt %	89.8	%	Throttle Motor Current	0.000	A
Accel Sensor Out No. 1	0.000	V	Throttle Motor Open Duty	0	%
Accel Sensor Out No. 2	0.000	V	Throttle Motor Close Duty	0	%
Accel Sensor Out No. 1	3.6	V	Throttle Motor Duty (Open)	13	%
Accel Sensor Out No. 2	4.4	V	Throttle Motor Duty (Close)	0	%
Accelerator Idle Position	OFF		Throttle Fully Close Learn	0.6	V
Accel Fully Close #1 (AD)	3.6	V	ETCS Actuator Power	ON	
Accel Fully Close Learn #1	10.5	ms	+BM Voltage	11.8	
Accel Fully Close Learn #2	0.000	A	Actuator Power Supply	ON	
Throttle Sensor Volt %	OFF		Actuator Power Supply	0.000	A
Throttl. Sensor #2 Volt %	OFF		Actuator Power Supply	OFF	
ST1	OFF		Actuator Power Supply	OFF	
System Guard	ON		Injector (Port)	0.00	ms
Open Side Malfunction	OFF		Injection Volum. (Cylinder1)	0.000	ml
Throttle Idle Position	OFF		Fuel Pump Speed Status	OFF	
			Vacuum Pump	OFF	

15. CONTINUED: INSPECT THE ACCELERATOR PEDAL ASSEMBLY OPERATION

a) Check the values by referring to the table below.

Techstream Parameter	Measurement: Range (Display)	Normal Condition	Diagnostic Note
Accel Sensor Out No. 1	APP sensor No. 1 voltage	Accelerator Pedal Released: 0.5 to 1.1 V Accelerator Pedal Fully Depressed: 2.6 to 4.5 V	Read value with ignition switch to ON (Do not start engine)
Accel Sensor Out No. 2	APP sensor No. 2 voltage	Accelerator Pedal Released: 1.2 to 2.0 V Accelerator Pedal Fully Depressed: 3.4 to 5.0 V	Read value with ignition switch to ON (Do not start engine)

-Campaign Complete-